

MAHLE

Industry

Suction Filters

Pi 1710

Nominal size up to 480

1. Features

Pumps incorporated in hydraulic systems must be protected from coarse contaminants which when not removed by any other filtering devices may gain access to tank.

MAHLE suction filters, series Pi 1710, stand out for their rugged construction and large filter surface area.

The filter surface is dimensioned to ensure long life at the proper corresponding flow rate.

The installation should be ahead of the pump in the tank for optimal protection.

The standard filter material is a 100 µm stainless steel wire mesh.

- Rugged construction
- Large filtering surface area
- Worldwide distribution

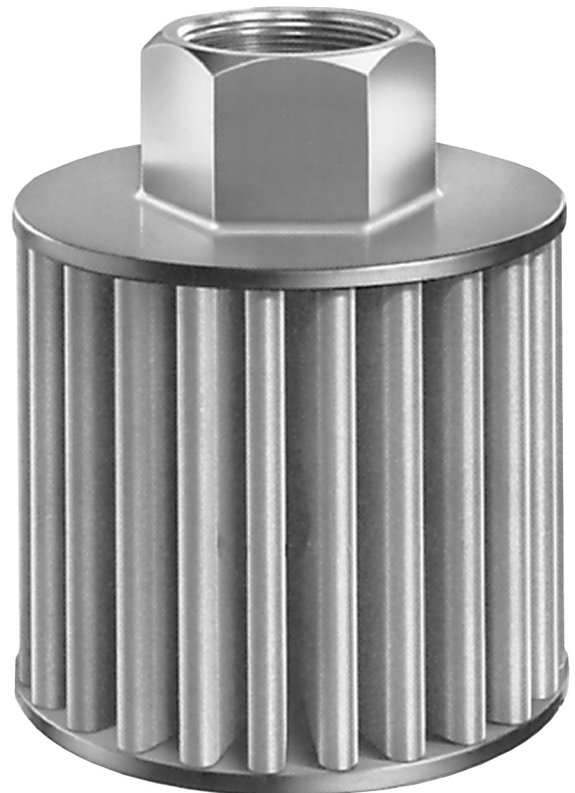

2. Flow rates/pressure drop curve

— 500 mm²/s
— 190 mm²/s
— 33 mm²/s

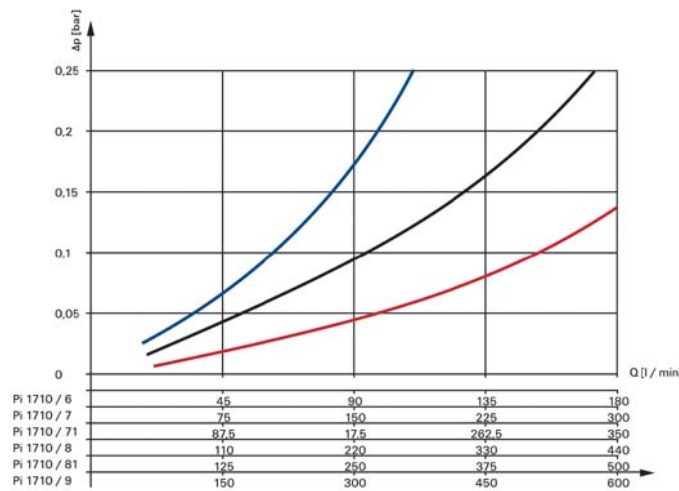
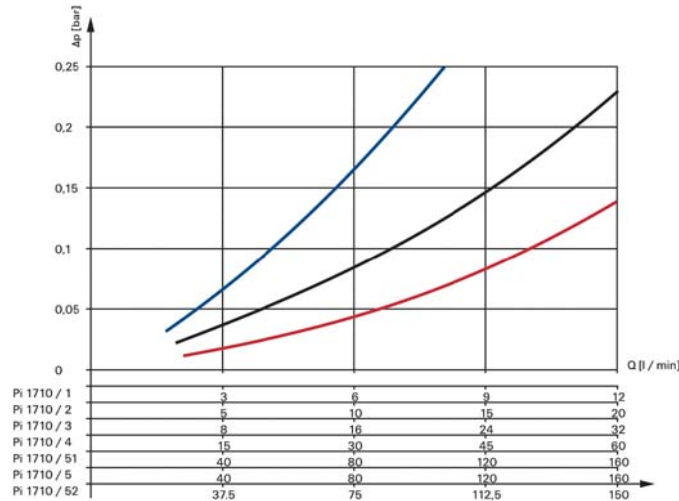

3. Order numbers

3.1 Housing design

Nominal size NG [l/min]	Order number	Type	Filter surface [cm ²]
10	77661598	Pi 1710/1	104
15	77661606	Pi 1710/2	104
30	77661614	Pi 1710/3	170
50	77661622	Pi 1710/4	394
60	77661697	Pi 1710/51	510
80	77661630	Pi 1710/5	642
120	77661705	Pi 1710/52	940
150	77661648	Pi 1710/6	1104
240	77661655	Pi 1710/7	1484
290	77661689	Pi 1710/71	1858
360	77661663	Pi 1710/8	2738
410	77661713	Pi 1710/81	3434
480	77661671	Pi 1710/9	3422

4. Technical specifications

Flow capacity:	10 to 480 l/min at 33 mm ² /s viscosity and 0.1 bar Δ p
Temperature range:	-10 °C to +120 °C
Degree of filtration:	100 μ m
Other ratings:	on request
Material of connecting port + end cap:	PA 6 GF 30
Material of end cap:	galvanized steel
Material of inner tube:	galvanized steel
Material of wire mesh:	stainless steel 1.4301

We draw attention to the fact that all values indicated are average values and do not always occur in specific cases of applications. Our products are continually being further developed. Values, dimensions and weights can change as a result of this. Our specialized department will be pleased to offer you advice.

We recommend you to contact us concerning applications of our filters in areas governed by the EU Directive 94/9 EG (ATEX 95).

The standard version can be used for liquids based on mineral oil (corresponding to the fluids in Group 2 of Directive 97/23 EC Article 9). If you are planning to use other fluids please contact us for additional support.

Subject to technical alteration.

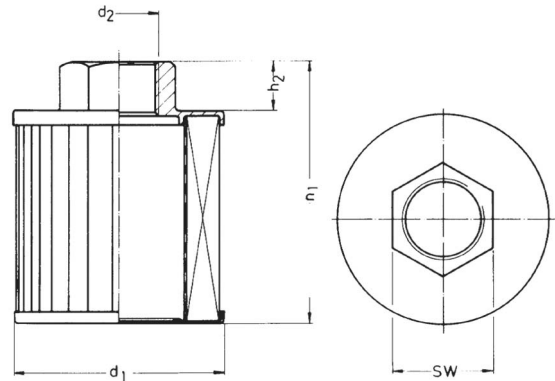

5. Dimensions

All dimensions except "d₂" in mm.

Type	d ₁	d ₂	h ₁	h ₂	SW	Weight [kg]
Pi 1710/1	46	G¼	59.5	18	22	0.10
Pi 1710/2	46	G3/8	59.5	18	22	0.10
Pi 1710/3	61	G½	53.5	13	27	0.14
Pi 1710/4	61	G¾	86.5	13	32	0.20
Pi 1710/51	87	G1	86.5	21	41	0.32
Pi 1710/5	87	G1	107.5	21	41	0.35
Pi 1710/52	87	G1	152.5	21	41	0.40
Pi 1710/6	99	G1¼	122	21.5	46	1.00
Pi 1710/7	99	G1½	159	28	50	1.00
Pi 1710/71	99	G1½	189	28	50	1.05
Pi 1710/8	131	G2	161	30	65	1.20
Pi 1710/81	131	G2	191	30	65	1.40
Pi 1710/9	131	G2½	198	37.5	80	1.50

6. Cleaning methods

a) Ultrasonic cleaning

Insert the contaminated suction filter element into an ultrasonic bath for approximately 3 minutes, then rinse in clean liquid. Afterwards, blow air into the filter from the clean side outward.

The cleaning effect is approximately 80-90 %.

b) Manual cleaning

1. Remove coarse external contamination in a separate cleaning tank using a brush and cleaning agent.
2. Place filter in unused cleaning liquid (approximately 20 minutes).
3. Wash filter with cleaning liquid from the inside to the outside. The cleaning effect is approximately 60-70 %.

Using either method be sure that no dirt is washed on the inside of the element.

MAHLE

Industry

MAHLE Industriefiltration GmbH
Schleifbachweg 45
D-74613 Öhringen
Phone +49 7941 67-0
Fax +49 7941 67-23429
industrialfiltration@mahle.com
www.mahle-industrialfiltration.com
78357287.04/2011