

## Automatic metal-edge filter AF 73 S / AF 93 S

with radial scraper cleaning  
housing in welded design, optionally with cyclone effect  
Connection size DN 50, DN 65, DN 80, DN 100, others upon request

### 1. Features

For the filtration and homogenization of low and high-viscosity fluids and pastes, MAHLE automatic metal-edge filters offer an extensive range of applications.

The compact inline filter systems can be equipped with automatic cleaning. The system is cleaned by rotating the cartridge against a spring actuated scraper. The AF93 S version is with integrated preseparator.

#### Advantages:

- Low life cycle costs because of no filter material consumption
- Cleaning can be performed without an interruption in filtration
- Precision separation using the surface filter principle
- Sturdy filter cartridge made of triangular stainless steel wire on a robust inner core
- Efficient filter cleaning for process stability
- Solid construction and high-quality materials for a long service life
- Modular MAHLE Vario system for optimal filter selection
- Material variants for a wide range of possible applications
- Service-friendly
- Worldwide distribution

#### Optional:

- Design acc. PED 2014 / 68 EU AD 2000; ASME VIII div. U-Stamp; EN 13445; GOST
- Designed on customers demand e. g. heating jacket; special materials; housing adaption.



## 2. Functional principle

The MAHLE metal-edge filter system is used for filtering and homogenizing an extensive range of liquids and pastes. The compact, inline filter system does not consume any filter material and therefore no disposal is required afterwards.

With the modular MAHLE Vario system on the MAHLE metal-edge filters it is possible to configure up to three filter cartridges above one another when high throughput rates are needed.

The filter can be cleaned either automatically or semi-automatically without interrupting operation. The concentrated solids are easily drained by opening the system for a short time.

The medium being cleaned is guided into the filter housing under pressure or in suction mode. It flows inward through the MAHLE filter cartridges. The solids are separated on the surface of the triangular wires of the filter cartridge.

The filtered fluid exits the filter housing at the top opposite the inlet connection. In the AF 93 S version, the integrated preseparator relieves the filter cartridge of coarse and heavy particles by means of a tangential flow around the tube.

Cleaning of the filter is performed either when a preset differential pressure limit is reached or after a specified cycle time elapses. Here the MAHLE filter cartridges are rotated against spring actuated scrapers. The special gap geometry of the filter cartridge ensures efficient cleaning.

The particles or agglomerates are skimmed from the surface and settle in the collection cone. The patented bearing in the filter cartridges (AKF system) prevents high axial forces and simplifies the cleaning procedure.

The residue that settles in the collection cone can be emptied through the drain valve either when the machine is stopped or during filtration.

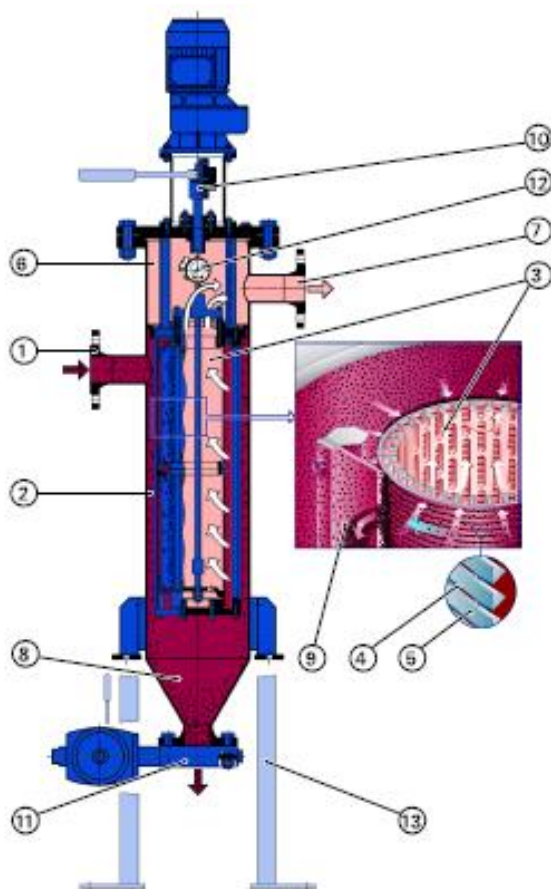

**On the MAHLE metal-edge filter AF 73 S, coiled cartridges, welded cartridges, and perforated foils can be used.**

### MAHLE coiled cartridge (standard):

- Optimal cleaning with sharp-edged triangular wire
- Large effective filter surface
- Precise, small gap widths
- High differential pressure stability and torsional strength
- Different material combinations possible



### MAHLE welded cartridge:

- High wear resistance to abrasive media
- Sturdy trapezoidal profile for high-viscosity media
- Continuous welded design
- Stainless steel construction

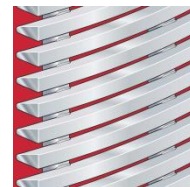

### MAHLE perforated foil:

- Specified sharp-edged hole diameter
- Asymmetric hole pattern
- Continuous welded design
- Manufactured in stainless steel or nickel
- Suitable for filtering fibrous waste material

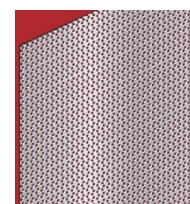

- 1 Inlet connection
- 2 Inlet plenum
- 3 MAHLE filter cartridge
- 4 Triangular wire winding
- 5 Triangular wire
- 6 Plenum for filtered fluid
- 7 Outlet connection
- 8 Particle collection cone
- 9 Scraper
- 10 Cleaning drive with gear motor or hand ratchet
- 11 Drain valve (automatic or manual)
- 12 Differential pressure indicator/switch
- 13 Feet optional

### 3. Technical data

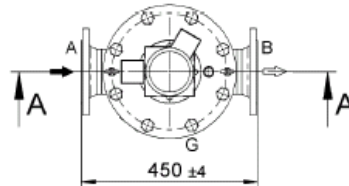
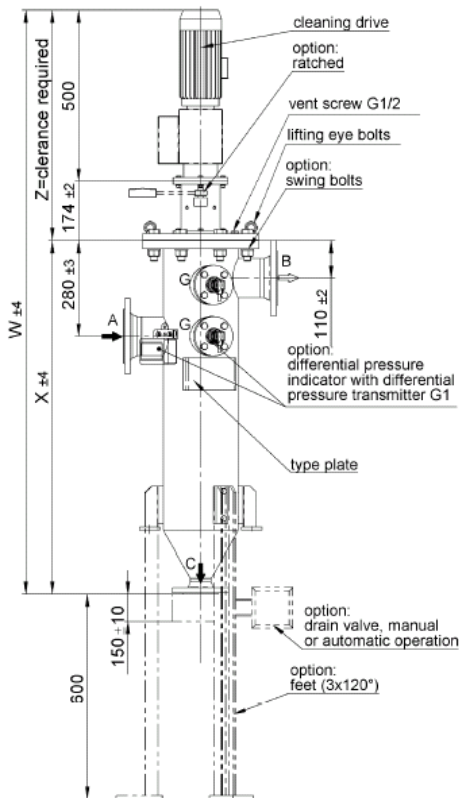

type	W (mm)	X (mm)	Z (mm)	volume (l)	weight (kg)	cleaning drive
AF7382-...-	1460	1300	1090	41	95	ratched
AF738-...-	1974	1300	1090	41	110	gear motor
AF7372-...-	1190	1030	820	32	85	ratched
AF737-...-	1704	1030	820	32	100	gear motor
AF7362-...-	920	760	550	22	75	ratched
AF736-...-	1434	760	550	22	90	gear motor

#### Filter data

Max. operating pressure: - 16 bar, optional 25 bar / 40 bar

Max. operating temperature: - 100 °C, optional 200 °C

Design according to: PED 2014 / 68 / EU

Materials:

- Housing and cover: Cast-Steel, 1.4571
- Internals: Cast steel and stainless steel, Al
- Bearing bushes: PTFE based
- Seals: FKM (Viton)
- Coiled cartridge: 1.4571 or Al, 1.4571 ( $\Delta p$  max. 30 bar)
- Welded cartridge: 1.4571 ( $\Delta p$  max. 10 bar)
- Element perforated foil: 1.4571 or Al, 1.4571 or Al, Ni ( $\Delta p$  max: 10 bar)

Connections and nominal diameters:

- A-inlet DN50, DN65, DN80, DN100
- B-outlet: DN50, DN65; DN80; DN100
- C-drain: DN50
- G-indicator: DN25

All threaded holes acc. to DIN 3852 form X flanges acc. to EN 1092-1/11B1/PN 16 (Standard, depending on operating pressure and temp.)

Drive shaft seal: Gland packing rings made of PTFE fibre with disc spring pretension

External finish: Synthetic resin primer, blue (RAL 5007)

#### Motor data

Spur gear motor  
Multirange winding

V	Hz	KW	rpm	A
$\Delta$ 230 ± 10%	50	0.18	17	1.11
$\Delta$ 400 ± 10%	50	0.18	17	0.65
$\Delta$ 266 ± 10%	60	0.22	21	1.11
$\Delta$ 460 ± 10%	60	0.22	21	0.65

Protection class: IP55, ISO-class F; output torque 95 Nm

#### Optional: Ex protection acc. to Atex 94/9/EC,

- Electrical design in Ex II 2G T3
- Mechanical design in Ex II 2G c T3

#### Optional:

- heating jacket
- ASME
- EN 13445

Other types available on request.

Note: Technical data is subject to change without notice.

## 4. Design and application

Cartridge type (see section 6)	Total surface in cm <sup>2</sup>	Gap width/hole width in $\mu\text{m}$ / effective gap surface in cm <sup>2</sup>															
		30	40	50	60	80	100	130	160	200	250	360	500	1000	1500	2000	4000
AF 6016	862	48	63	77	91	117	142	176	206								
AF 6026	862			50	59	77	95	119	142	170	203	264	328	473	555	608	
AF 6036	862	48	63	77		117	141	175	206								
AF 6046	862			50		77	94	119	141	170	202	263	326	471	553	606	
AF 6066	836												184	302	385	446	
AF 6076	836						77	97	117	141	169	224	282				
AF 6086	836			56	67	89	112										
AF 50116	836						188			155			188				
AF 50126	836						82			147			228				
AF 50136	836						82			147			228				
AF 6006	836													190	278	190	337

 recommended design

### Cleaning and emptying

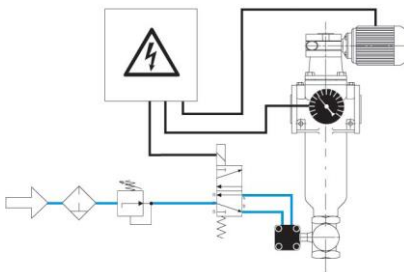

#### Fully automatic operation:

Filtration usually occurs under pressure. The filter is cleaned after a programmed time or a preset number of cycles or according to the differential pressure. We recommend cleaning the system at approximately 4 times the initial differential pressure. The cleaning motor runs for about 10 seconds (about three turns of the filter cartridge). This is sufficient for a thorough cleaning. In certain rare cases it may be necessary to run the motor continuously. The drive shaft is always turned clockwise. The filter is emptied by opening the drain valve. This can either take place synchronously with cleaning or be time or cycle controlled, depending on the residue concentration. The opening time of the drain valve can be set between 2 and 6 seconds. The filter can be emptied in suction mode using a buffer or by interrupting the filtration process.

Semi-automatic and manual operation are also possible.

See the Instruction Manual for further information.



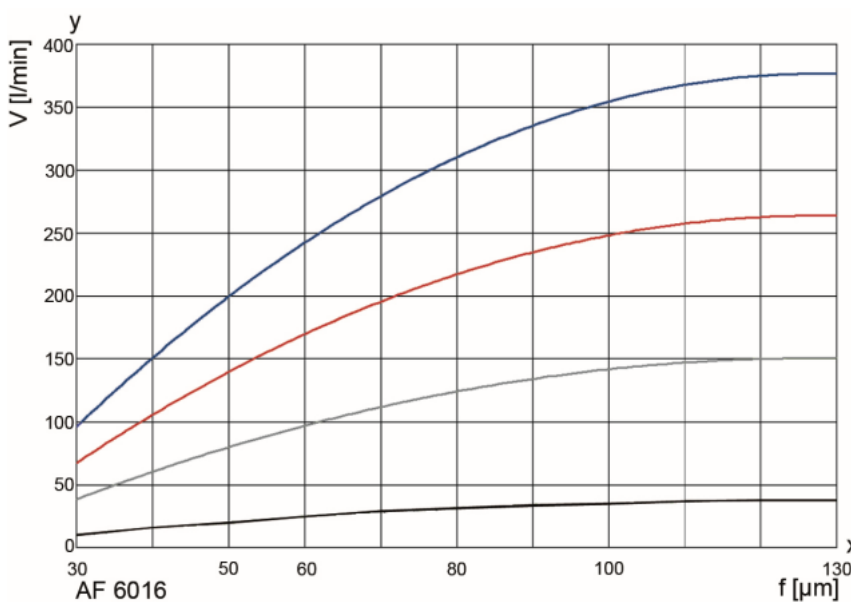

## 5. Performance curves



The curves represent the volumetric flow through the entire filter system (filter housing including for example one cartridge) and refer to a differential pressure of 0.3 bar. Specific information about process data is essential for reliable operation of an automatic filter.

Important note on performance curve!  
It's an example of element AF 6016.  
The number of elements per filter results from type number key in point 6.

Viscosity in mm<sup>2</sup>/s

-  1 mm<sup>2</sup>/s
-  33 mm<sup>2</sup>/s
-  100 mm<sup>2</sup>/s
-  500 mm<sup>2</sup>/s

y = volumetric flow V [l/min]  
x = gap width f [ $\mu\text{m}$ ]

## 6. Type number key

### Type number key with selection example for AF 7373-521-50200 S1

#### Size / number of filter cartridge columns / function

**AF 73** 1 filter cartridge column Ø 110 mm / metal-edge filter with radial cleaning

**AF 93** 1 filter cartridge column Ø 110 mm / metal-edge filter with radial cleaning and preseparator through the cyclone effect

#### Number of filter cartridges

- 6** 1 filter cartridge per column
- 7** 2 filter cartridges per column
- 8** 3 filter cartridges per column

#### Cleaning drive

- 3** Gear motor 230/400 V, 50 Hz or 266/460 V, 60 Hz
- 4** Gear motor 230/400 V, 50 Hz or 266/460 V, 60 Hz Ex II 2G T3

#### Inlet and outlet connections

- 3** DN 50 EN 1092-1 / 11 B1 / PN 16      **5** DN 80 EN 1092-1 / 11 B1 / PN 16
- 4** DN 65 EN 1092-1 / 11 B1 / PN 16      **6** DN 100 EN 1092-1 / 11 B1 / PN 16

#### Permissible operating pressure in bar (housing/cover)

- 1** PN10
- 2** PN 16
- 3** PN 25
- 4** PN 40

#### Material Seal FKM, bearing PTFE

- 1** Standard: Housing in carbon steel, internals in carbon steel, EN-GJS-400-15, aluminium
- 2** Standard: Housing in stainless steel 1.4571, internals in stainless steel
- 3** Standard: Housing in carbon steel, internals in stainless steel

#### Differential pressure indicator and gauge

- 4** Pis 3170, digital  $\Delta p$  gauge, 2 switching levels settable from 0 to 16 bar.
- 5** Pis 3175 differential pressure gauge with pressure transmitter
- 9** Pis 3180 explosion-protected differential pressure gauge with pressure transmitter Ex II 2G Exd

#### Valves and control throttles

- 0** Without/special version

#### Drain valve

- 1** Ball valve, manual
- 2** Ball valve, electropneumatic 24 V
- 3** Ball valve, electropneumatic 230 V
- 4** Ball valve, electric 24 V
- 5** Ball valve, electric 230 V

#### Cleaning valve

- 0** Without

#### Optional features

- 0** Without / other version

AF 73    7    3    -5    2    1    -5    0    2    0    0    - XXXX(end number for special version)

#### End number

#### Special version

3001	Standard filter insert (complete), without housing and without drive
3002	Standard filter insert (complete), without housing, with drive
3400	With double jacket for heating / cooling PN 10 bar
3700	PTFE seals
4166	3 scrapers per filter cartridge
Others	Upon request

**Type number key with selection example for coiled and welded cartridges for AF 60 and perforated foil AF 50**

**Series**

**AF 60** Coiled cartridge or welded cartridge with triangular wire winding

**AF 50** Perforated foil

Material	Inner core	Filter medium	Clamp rings	Wire width in mm
<b>Welded cartridge</b>				
1	Al	1.4571	1.4571	0.5
2	Al	1.4571	1.4571	0.8
3	1.4581	1.4571	-	0.5
4	1.4581	1.4571	-	0.8
<b>Coiled cartridge</b>				
6	-	1.4571	1.4571	1.8
7	-	1.4571	1.4571	1
8	-	1.4571	1.4435	0,75
<b>Perforated foil</b>				
11	Al	Ni	1.4571	-
12	Al	1.4571	1.4571	-
13	1.4571	1.4571	1.4571	-

**Length** Diameter x length in mm  
6 110x265

**Gap width/rating in µm (see 4. Design and application)**

<b>003</b>	30 µm	<b>010</b>	100 µm	<b>036</b>	360 µm
<b>004</b>	40 µm	<b>013</b>	130 µm	<b>050</b>	500 µm
<b>005</b>	50 µm	<b>016</b>	160 µm	<b>100</b>	1000 µm
<b>006</b>	60 µm	<b>020</b>	200 µm	<b>150</b>	1500 µm
<b>008</b>	80 µm	<b>025</b>	250 µm	<b>200</b>	2000 µm

**Hole size/grade in µm (see 4. Design and application)**

<b>010</b>	100 µm
<b>020</b>	200 µm
<b>050</b>	500 µm
Other grades upon request	

**AF 60**    **1**    **6**    **- 010**

## 7. Spare Parts

### Metal-edge or coiled cartridge

Item	Designation	Order number	
		FKM/C-Steel	PTFE/Stainless steel
1	Bush kit		78358947
2	Seal kit (complete)	77982143	77982150
3	Scraper		71116805
4	Spring set		70350654
5	Filter cartridge	See name-plate	

### Perforated foil cartridge

Item	Designation	Order number
6	Scraper PU (complete)	70531132
7	Scraper PTFE (complete)	70379502
8	Scraper PU (wear part)	70378953
9	Scraper PTFE (wear part)	70370568

Please contact us for detailed technical information, any open questions about options, accessories and for general expert advice. Completion of the relevant questionnaire would facilitate in the coordination of all important parameters. Comprehensive documentation on our filter range, filter cartridges and accessories can be provided. For information on installation and operation, please see the Instruction Manual.

MAHLE Industriefiltration GmbH  
Schleifbachweg 45  
D-74613 Öhringen, Germany  
Phone +49 07941 67-0  
Fax +49 07941 67-23429  
industriefiltration@mahle.com  
www.mahle.com  
10/2015